



LAKOS
Liquid • Solids Separation Systems®

For Automotive Manufacturing
FLUID RECYCLING SYSTEMS



Effective, Comprehensive Separation Solutions

Fluid use and re-use takes place everywhere in an automotive plant.

Powertrain divisions. Machining centers. Assembly plants.

High-profile fluid processing and environmentally-sensitive recycling requirements demand better process system management.

Removing unwanted solids is an opportunity for reduced operating costs and improved productivity.

ISO14001... This standard of environmental management demands the recognition and minimization of harmful waste solids/liquids. It requires consistent and continuous process-improving techniques. It expects reliable performance. It promises a high standard of compliance and the likelihood of widespread operational savings. LAKOS, in fact, is completely compatible to these principles and standards, advancing your framework for certification.

What Makes LAKOS Different Is What Makes LAKOS Better

You can remove solids from liquids with a variety of products. You know the drawbacks of traditional filtration. You have the opportunity to make a much better choice.

- ▶ Extends life of process fluids.
- ▶ Protects equipment from fouling and abrasive wear.
- ▶ Controls/eliminates liquid/solids waste.
- ▶ Reduces system downtime and maintenance.
- ▶ Keeps fluid systems at optimum efficiency.
- ▶ Increases production; allows faster machining.
- ▶ Improves parts finish.
- ▶ Reduces defective parts/scrap.

LAKOS By Comparison

▼ Features and Benefits

No moving parts to wear out.

No screens, cartridges, cones or filter elements to clean or replace.

No backwashing.

No routine maintenance or downtime requirements.

No standby equipment needs.

Low and steady pressure loss.

Easily automated.

Compact, space-saving profiles.

Little or no liquid loss.

Effective solids concentration for easy disposal/recovery.

▼ Compare to any filtration technique

Particle size removal.

See page 2 for LAKOS details.

Pressure loss.

LAKOS Separators perform with a pressure loss of only 3-12 psi (0.2-0.8 bar).

Liquid loss & solids handling.

See page 6 for LAKOS details.

Replacement parts.

LAKOS requires no replacement parts.

Maintenance requirements.

Easily automated; no system shutdowns. See page 6 for more details.

Space requirements.

Lowest space requirements of any filtration/separation technology.



LAKOS

Centrifugal-Action Liquid-Solids Separation Technology

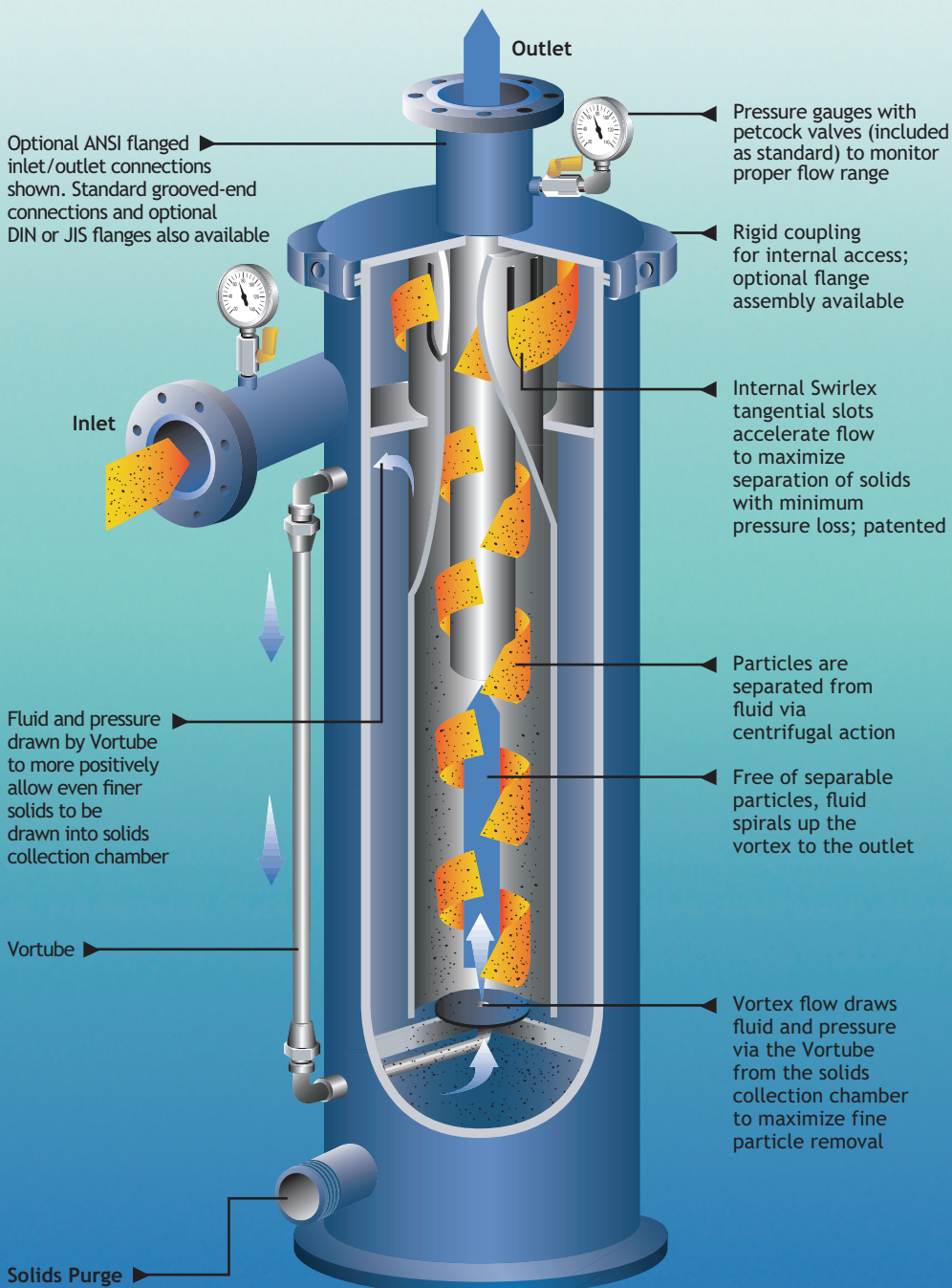

Solids Purge
 LAKOS Automatic Purging and Solids Collection Systems available (see page 6) for complete systemization and maintenance-free operation

Effective Solids Removal Performance

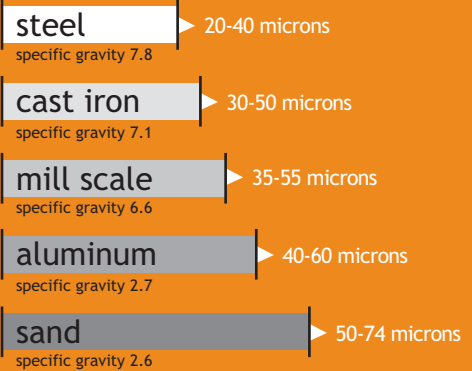

Flow rate & velocity are the key factors of LAKOS performance, creating centrifugal-action to remove particles heavy enough to be influenced by the g-force of this action. It is therefore logical that particle weight is the governing measure of LAKOS performance, translated to particle size by the chart above. Heavier particles are predictably easier to remove at smaller sizes.

Recirculation of fluids through a LAKOS Separator further enhances particle removal, resulting in finer solids performance (as fine as 5 microns) and overall solids volume reduction. In many instances, particle characteristics and application experience have shown performance above and beyond general expectations. Consult LAKOS for further details and on-site testing possibilities.

Opportunities for Improved Productivity

Costly problems demand effective solutions. Effective solutions save time and money.

The opportunity therefore exists for you to create an effective payback scenario in your operations. Examine these typical LAKOS application concepts, applied throughout the automotive manufacturing world. Consider those who have already decided on the value of LAKOS.

Discover your opportunities for LAKOS Separators.

Spray nozzle protection

Heat exchanger protection

Pre-filtration

Pit/sump accumulation prevention

Waste minimization

Central Coolant Systems Full-Stream Protection

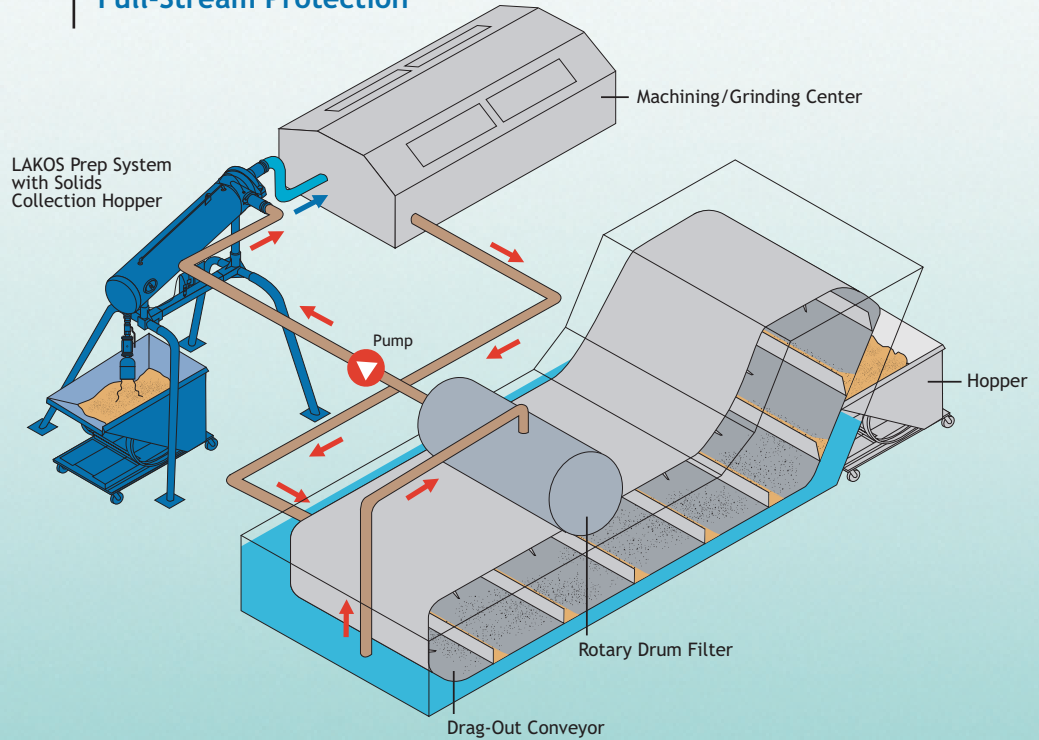

Deluge Wash Baths Nozzle Protection and Solids Accumulation Control

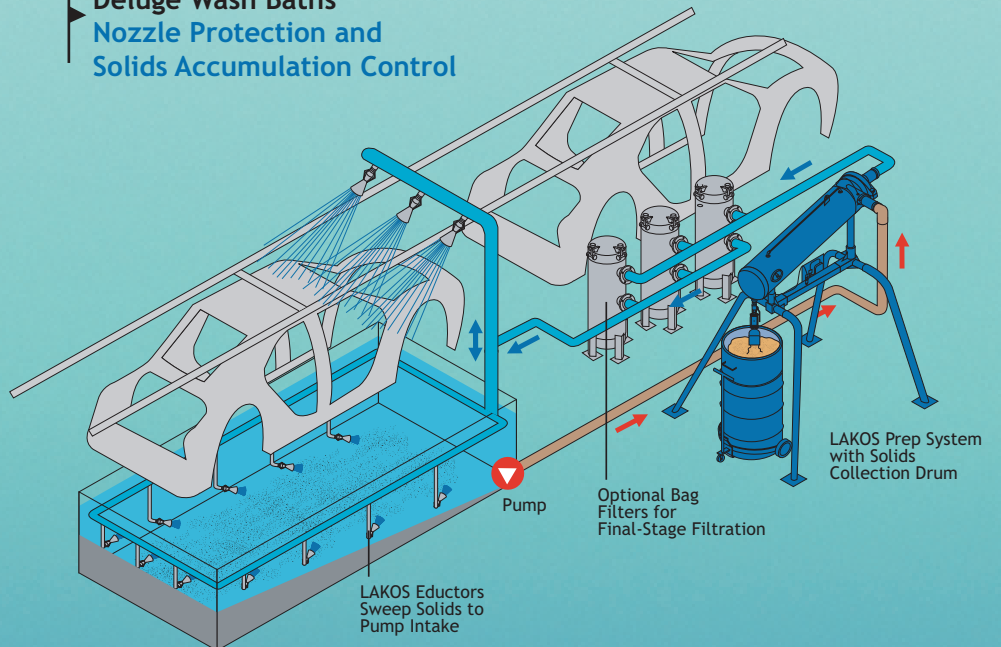

Machining/Grinding Centers Coolant Filtration/Recycling

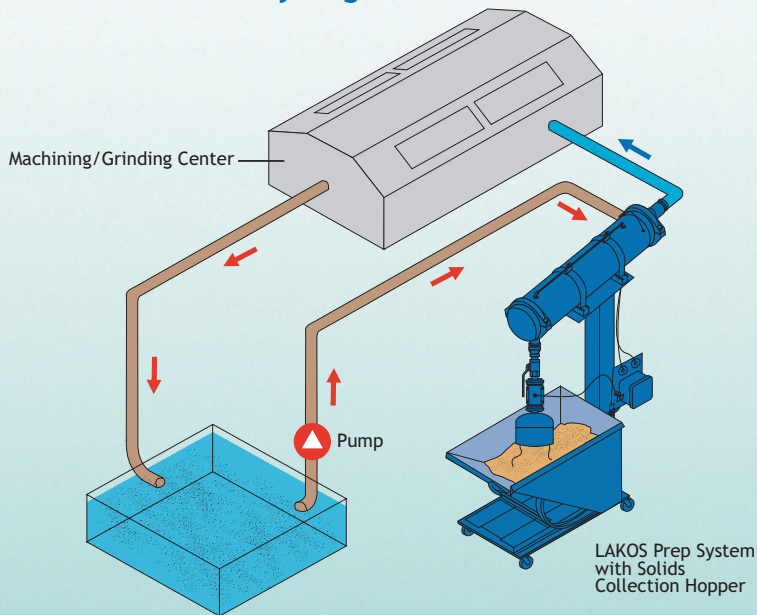

Robotic Welders Cooling Water and Heat Exchanger Protection

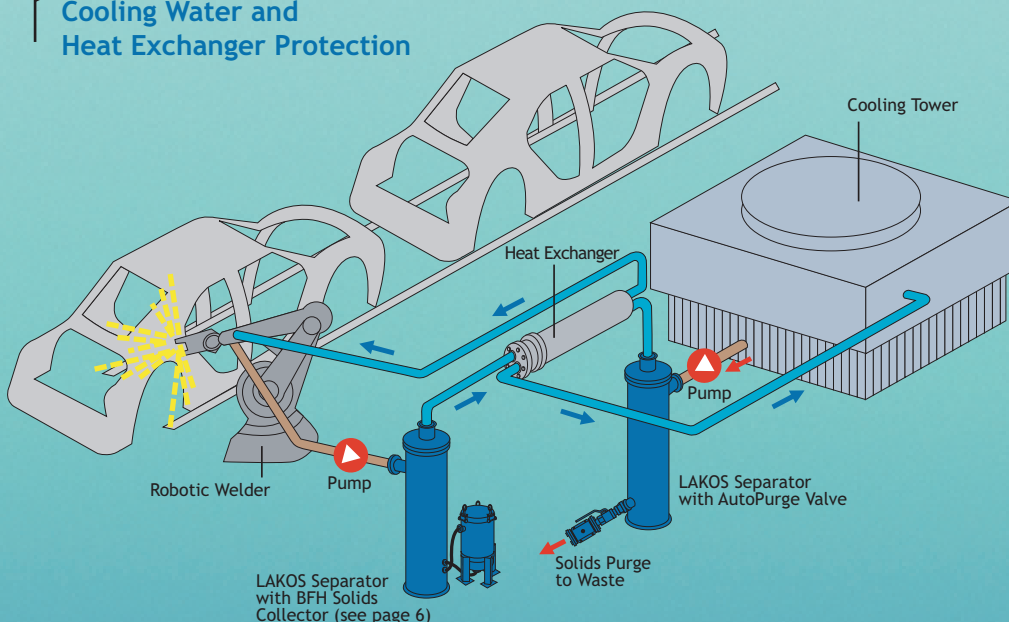

Applications

Cooling water lines for robotic welders become clogged

Grit & scale foul the recirculated water lines and interrupt proper cooling, resulting in overheating, equipment damage, downtime, excessive maintenance and lost productivity.

Body prep & deluge wash baths accumulate unwanted solids

Dirty water reduces cleaning efficiency and increases surface blemishes & re-work. Settled solids must be removed, forcing tank shutdown, water loss, maintenance, waste handling and lost productivity.

Machining centers suffer from dirty coolant

Grinding & finishing processes lose their efficiency, wheel dressing becomes excessive, re-work increases, coolant degrades with solids & bacteria to require high replacement frequency. Shutdowns occur, maintenance routines increase and productivity suffers.

Pre-rinse & post-rinse processes are fouled with solid contaminants

Spray nozzles, quench tanks, rinse baths and other fluid processes become fouled with solids. Surface blemishes and rework cause efficiency problems. Maintenance increases. Shutdowns occur too often. Productivity suffers.

Quench tanks are fouled with solid contaminants

Cooling, cleaning and treatment baths can quickly accumulate troublesome solids. Blemishes, re-work and process efficiency suffers. Dredging, liquid loss, downtime, maintenance and lost productivity are inevitable without effective protection.

Cooling towers lose their efficiency

Spray nozzles become fouled. Tower basins fill with unwanted solids. Unwanted bacteria contaminates the tower water. Heat exchangers become plugged. Energy costs rise. Blowdown wastes more water. Chemical usage increases. Maintenance and downtime cut into productivity.

Carwash operations face costly maintenance to remove solids

Build-up in the recycling pits. Plugged spray nozzles. Sump clean-up. Excessive shutdown routines. More productivity loss.

Separator Models

The actual flow rate of your system is key to proper model selection. Internal accessibility enables the removal of unusually large or difficult solids and provides for internal coatings to protect against corrosive/aggressive liquids/solids. Satisfying all the material and manufacturing requirements of the American Society of Mechanical Engineers, LAKOS also offers A.S.M.E. Code construction.



▶ Flow Range:

Models available for flow rates of 3 US gpm to 12,750 US gpm (0.5 - 2895 m³/hr). Flow rate (not pipe size) is key to proper model selection.

▶ Maximum Pressure Rating:

150 psi (10.3 bar); higher pressures also available.

▶ Pressure Loss Range:

3-12 psi (0.2 - 1.0 bar)

▶ Inlet/Outlet Connections:

Standard grooved-end pipe. May also be specified with ANSI, DIN or JIS flanges. Smaller models available in NPT, JIS and other threaded connections.

▶ Special Coatings:

Epoxy, Scotchkote™, Kanigen™, nickel.

▶ Process Treatments:

Electropolished, electroplated, heat-treated, sand-blasted (unpainted), primer only.

▶ Other Options:

Low or vertical profiles, exterior modifications, high pressure construction, packaged/multi-stage/skid systems and more.

▶ Material Specifications:

Standard carbon steel; also available in stainless steel, fiberglass-reinforced polyester (FRP), Monel™ clad steel, AR steel (abrasion-resistant), low-alloy steel, industrial-grade PVC plastic (KXL Series) and U.S.D.A. approved materials. Consult factory for special requirements.

Prep Systems: For A Total Filtration Solution

The LAKOS PRX PREP System concept provides a turn-key solution, ready to install and start-up. Value-added componentry reduces overall engineering, purchasing, welding, plumbing, electrical and installation costs. Complete systemization and compatibility. Proven reliability and convenience. Single source value.

System shown with LAKOS SCH Series Solids Collection Hopper. See below for other options.



Out of the fluid.
Out of the filter.
Out of your facility.

Your complete and exclusive LAKOS solution includes not only the removal of unwanted solids from your process liquid flows, but also the concentration, collection and placement of those separated solids where desired and in the condition desired. Automatic purging and other devices provide efficient means for effective solids transfer from any LAKOS Separator. Specially designed solids-collection systems offer a range of handling options to satisfy the toughest requirements.

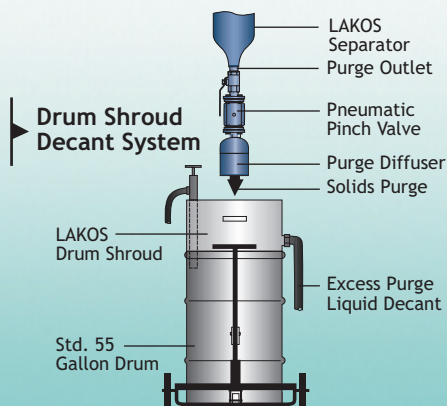

Purge Transfer/Control Options

LAKOS Automatic Purge Valves

Choice of standard motorized ball, pneumatic pinch and fail-safe pneumatic ball; specialty valves also available.

LAKOS Purge Diffusers

Controls splashing and turbulence when purging into open vessels.

LAKOS Purge Liquid Concentrators

Automatically reduces purge liquid loss by as much as 98% compared to open purging.

LAKOS BFH-Solids Collector

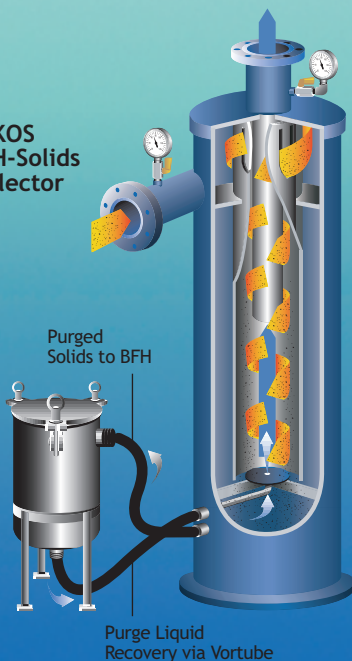

Solids Handling Options

LAKOS BFH Solids Collection & Fluid Recovery System

Captures and concentrates solids in a closed vessel, returning all system fluid to system use via the LAKOS Vortube concept.
Capacity: 720 cubic inches (12 liters).

LAKOS Drum Shroud Decant System

Utilizes the full solids-collection capacity of a standard 55 gallon drum, allowing excess purged liquid to decant/return to system use or to a suitable drain.
Capacity: 12,700 cubic inches (208 liters).

LAKOS DrumBagger System

Incorporates three large solids collection bags into an open, specially-fitted 55-gallon drum, returning all purged fluid via decant to system re-use.
Capacity: 2,160 cubic inches (30 liters).

LAKOS Rollaway Hopper

High capacity solids collection, internal weir for cleaner liquid decant and convenient rollers for easy handling.
Capacity: 41,472 cubic inches (680 liters).



A Tradition. A Heritage.

Since the mid-1940's, Claude Laval Jr.'s inventions have been solving problems. A miniature camera that takes pictures deep into water wells. A well casing repair device that restores the effective use of a water well. And, the first sand separators, which protected submersible and turbine irrigation pumps. Today, the LAKOS Separator is a proven solution for process industries, public water systems, heat transfer systems and more. Complete and engineered solutions for the removal and concentration of troublesome solids. Total liquid recycling. More and more problems solved.



The LAVAL history features more than 150 U.S. and foreign patents. Its focus is clearly filtration. Its complete line of products includes separators, sand filters, self-cleaning screen filters and pump intake screens for a broad range of industries. Experience, quality, performance and integrity. Satisfying real problems with value-oriented solutions. It is our heritage. It is exclusively what we do best. From the 100,000 + square foot manufacturing, sales, marketing and engineering headquarters in California and strategic secondary manufacturing and warehousing, Claude Laval Corporation directs its operations with a worldwide network of technically-trained distributors. We welcome your technical/application inquiries. We encourage you to tour our facilities. We are your reliable source for experienced application expertise.

LAKOS

Liquid • Solids Separation Systems®

A Division of Claude Laval Corporation
Not Connected With The DeLaval Separator Company

USA and Worldwide

1365 North Clovis Avenue
Fresno, California 93727

Toll-Free: (800) 344-7205
(USA, Canada and Mexico)

Telephone: (559) 255-1601
Fax: (559) 255-8093
Internet: www.lakos.com
e-mail: info@lakos.com

Distribuido por:

**InduServices**
servicios industriales

Of.: Pasaje E N43-71 y Edmundo Carvajal "Edf. El Ferrol" Piso 1
Quito Ecuador Telf. (593) 225 0090 / (593) 603 5925
induservices@uio.satnet.net www.induvicecuador.com

LS-588A (Rev. 11/03)

 Printed on recycled paper